



IRONING PRESSING MACHINERIES – FUSING PRESSES

INSTRUCTION MANUAL FLEX FS S+B



A FEW WORDS FROM THE MANUFACTURER

The ironing table “FLEX FS” is a machine of high advanced technology, unique in its kind. It is manufactured according to the International and European technical specifications and safety standards from a company with experience since 1969 in its sector. Congratulations for your choice!

INSTALLATION

Put the table in the required place and adjust the little foot No 13. Make sure, that is totally aligned.

ELECTRICAL CONNECTION

For the electrical connection and everything about the power supply, please follow carefully the instructions of the electric diagram attached to the machine. Please pay attention to the warning signs symbols on the machine. In case you have a single phase machine 230V, connect the machine to the power through the plug No 22 into the socket 230V/16A. The connection should be done with 3-phase 3X1,5mm (1 phase, 1 neutral, 1 grounded). The power should be provided with a fuse 10A. If the machine is 400V/3 phase, the connection should be made to a 5-poles cable 5X1,5mm (3 phase, 1 neutral, 1 grounding). The power should be secured with a 3-poles safety switch (3X10A).

CAUTION ! The manufacturer denies any liability for any injury or accident that might be caused due to faulty power networks or due to faulty connections made by unskilled persons.

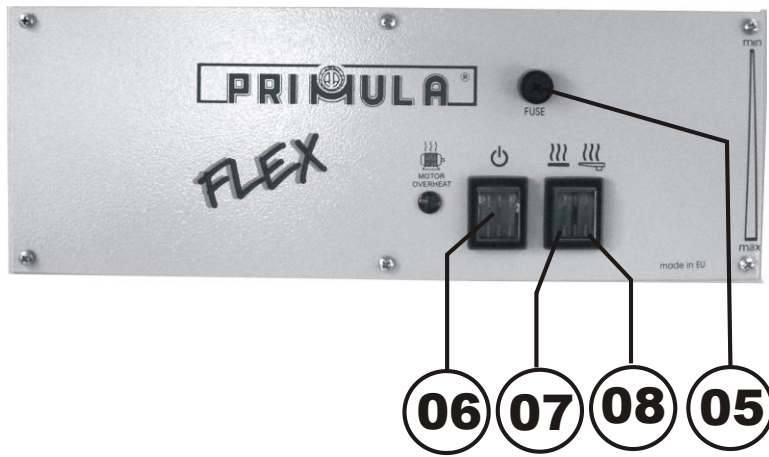

OPERATING INSTRUCTIONS

- Turn on the main switch No. 06
- Switch the thermostat No. 04 to temperature 110°C during the winter and to 90°C during the summer.
- Whenever you want to use the suction just press the left pedal No 22.
- Adjust the steam quantity of the steam generator in proportion to the suction performance of the table, in order to avoid steam liquidation on the working surface. The refined fabrics require small quantity of steam, while the gross fabrics require big quantity of steam.
- The ironing buck's heating is activated when you press switch No 8 to position I.
- In case the table disposes Vario iron's lifting system (optional) hook the steam iron from the balancer and adjust the distance of the steam iron from the working surface (approximately 5cm). After finishing ironing unhook the steam iron from the balancer and put it on the iron rest mat.

* In case your table disposes a blowing system of air:

- Adjust the volume of the blowing air with the lever according to the requirements of the fabric (weight, quality , etc.) from the knob which is placed in the main body of the machine
- In order to use the blowing push with your foot pedal No.

MAINTENANCE

- Make sure that the covers of the table and the ironing buck remain clean, in order to have high performance of suction and blowing air. Wash the blue polyester fabric and the foam blue once in a week in the washing machine (30-40 °C).
In case you use felt molleton instead of blue foam, do not put it in the washing machine, but wash it on hand. Replace them regularly, in order to keep high suction and blowing performance.
- Clean the dust of the fan wheel /impeller No 02 at least 2-3 times per year.
- Periodically clean and grease the arm's as well as the buck's bearings.
- Periodically clean the internal parts of the table as well as the electronic circuit by using compressed air.
- Keep the machine clean.

CAUTION! Before doing maintenance work, please disconnect the machine from the electrically power supply.

TROUBLESHOOTING

The vacuum does not function properly

- Check if there is power supply
- Check if the power feeding cable is for some reason cut off
- Check the fuse 12A which is inside the fuse case No 05
- Check if the suction's button pedal No 9 is faulty
- Check if motor No 01 is for some reason damaged
- Check the relay No 13
- Check the electronic circuit No 18

The blowing of air does not function

- Check if the blowing's button pedal No 9 is damaged
- Check the electronic circuit No 18
- Check the relay No 13
- Check the motor No 1

The heating of the working surface is not activated

- Check if the fuse 12A inside the fuse case No 05 is burnt out. Replace it.
- Check if the safety thermostat No 40 is faulty. Replace it.
- Check if the thermostat No 64 is faulty. Replace it.
- Check if the heating element No 34 is burnt out. Replace it.

The heating of the ironing buck is not activated.

- Check the cable and the plug of ironing's buck power supply
- Check the switch No 08 for the heating of the ironing buck
- Check the heating element of the ironing buck

The machine operates loudly

- Check if the ball bearings of the motor are faulty. Replace them.
- Check the impeller to be sure, that there is no dust which could cause the vibration.

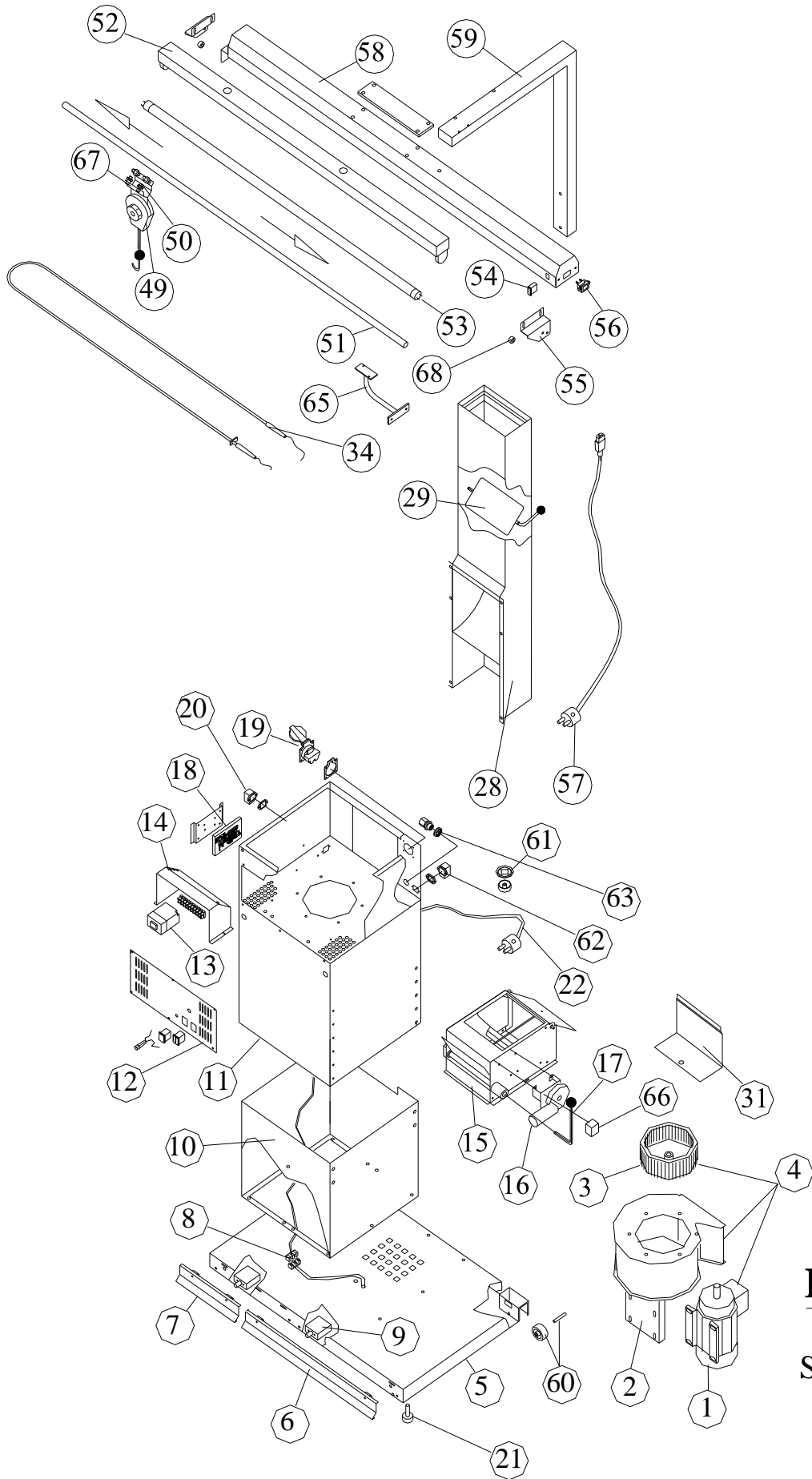

PRIMULA
FLEX FS
SPARE PARTS

Spare parts list FLEX FS

No	CODE	DESCRIPTION
1	302-22-001	Electric Motor 0,75HP/400V/50HZ - 3 N
	302-22-001-1	Electric Motor 0,75HP/230V/50HZ - 1 N
	302-22-001-2	Electric Motor 0,75HP/220V/60HZ - 1 N
	302-22-001-3	Electric Motor 0,75HP/110V/60HZ -1 N
2	302-22-002	Metallic cup
3	302-00-003	Fan wheel Ø180
4	302-22-004	Vacuum complete
5	192-22-005	Base of table 1365
6	192-22-006	Vacuum pedal 1365
7	192-22-007	Blowing pedal 1365
8	192-22-008	Terminal block for the connection of the vacuum button pedal
9	302-00-005	Vacuum button pedal
10	192-22-010	Base No 1 male
11	192-22-011	Base No 2 female
12	192-22-012	Label
13	302-00-010	Relay
14	192-22-014	Circuit's case
15	192-22-015	Vacuum and Blowing interchange system
16	302-03-006	Flap Motor 12V/DC
17	192-22-017	Regulation lever of blowing
18	302-22-018	Electronic circuit
19	302-03-029	Socket 6A
20	302-22-020	4-poles corner socket
21	302-02-014	Leg for the regulation of table
22	302-22-022	Cable of power supply 3X1.5mm with plug
	302-00-014	Cable of power supply 5X1.5mm
23	302-22-023	Power supply cable of heating element
24	192-22-024	Metallic base of iron
25	107-03-003	Silicon iron rest mat
26	302-00-041	Hanger of the iron's cables
27	107-01-000	Antenna
28	192-22-028	Chimney
29	192-22-029	Tamber of chimney
30		
31	192-22-031	Metallic cover
32	192-22-032	Board's mechanic tamper
33	302-22-033	Springs with clips
34	302-01-014	Heating element 1KW 230V
35	192-22-035	Board 1365
36	192-22-036	Metallic gauze
37	302-22-037	Lattice fabric white
	302-22-038	Foam layer 1365

No	CODE	DESCRIPTION
38	302-22-038-1 302-22-038-2	Vacufix layer 1365 Felt molletone 1365
39	302-22-039	Cover Fabric of board blue TPF-POL
40	302-01-010	Safety thermostat 145°C
41	192-22-041	Corner's tamper
42	192-22-042	Swivel arm's corner
43	192-22-043	Swivel arm's bronze gasket
44	192-22-046	Bearing of swivel arm
45	192-22-043	Swivel arm's bronze gasket
46	192-22-044	Female bearing of arm
47	192-22-047	Wheel of swivel arm
48	192-22-048	Arm of buck
49	302-00-051	Iron's suspension
50	302-00-049	Stretcher suspension
51	192-22-051	Suspension's bar
52	192-22-052	Lighting
53	302-22-053	Fluorescent lighting
54	302-22-054	Lighting's switch
55	192-22-055	Blade of bar support
56	302-22-056	Lighting's socket
57	302-22-057	Cable of lighting power
58	192-21-055	Plate of lighting
59	302-22-059	Corner of vario
60	302-01-015	Plastic wheel
61	302-22-061	Thermostat knob
62	302-22-020	4-poles corner socket
63	302-22-063	Gland
64	302-00-012	Thermostat of table 110C
65	192-22-065	Base of condenser TS (optional)
66	302-21-024	Relay 12V/DC
67	302-22-067	Ball bearing of stretcher's suspension
68	302-22-068	Elastic stop
69	192-22-069	Base of heating element

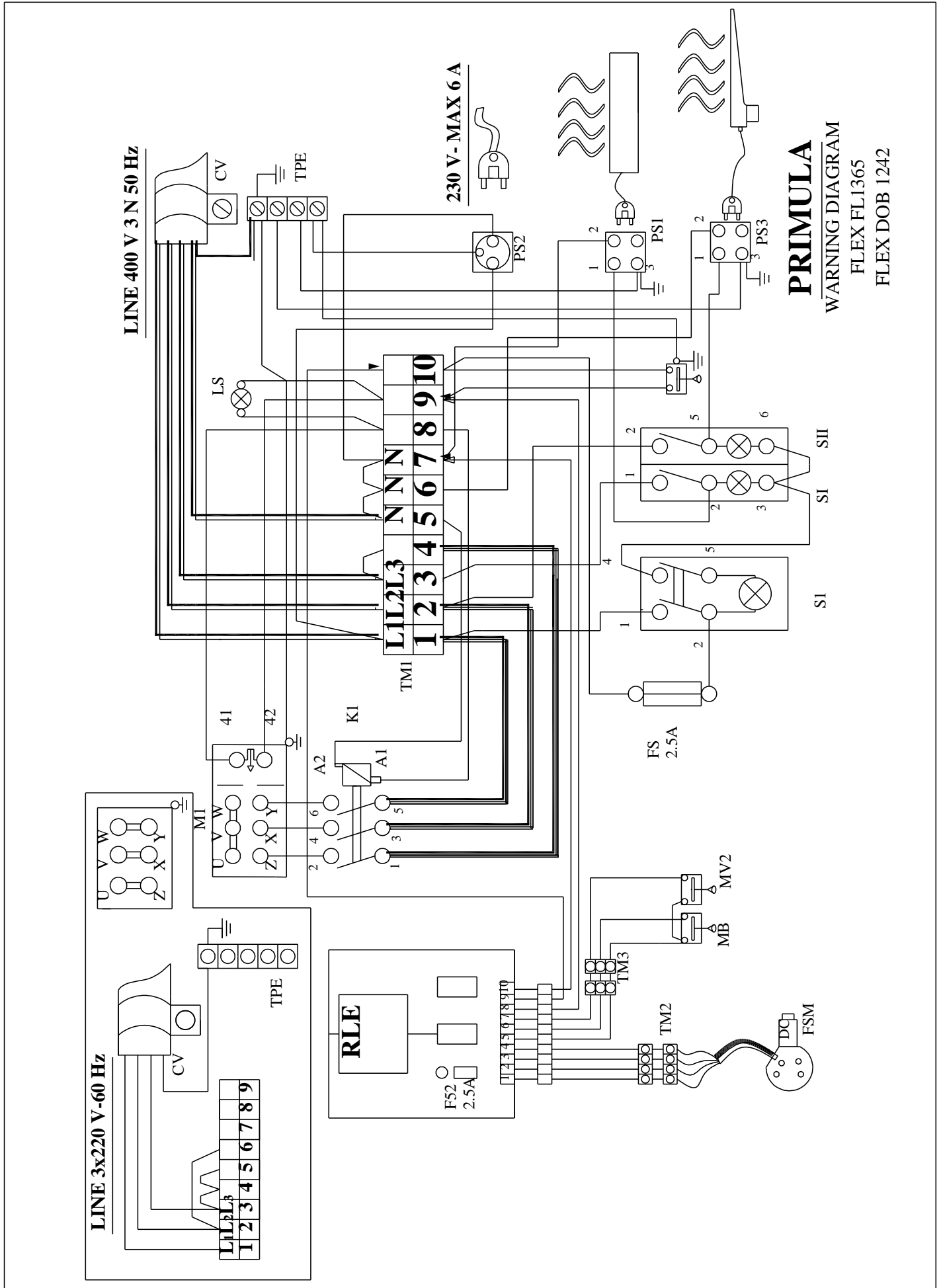

ELECTRICALL CIRCUIT

<u>Symbol</u>	<u>Articel</u>	<u>Description</u>
RLE	302-22-018	Electronic circuit
FSM	302-03-006	Flap Motor 12V/DC
TPE	302-22-071	Brass terminal block of grounding
PS1	302-22-020	4-poles socket of working surface
PS2	302-03-029	Socket
PS3	302-22-020	4-poles socket of buck
TM1	302-22-072	Power supply terminal block
TM2	302-22-073	Flap motor terminal block
TM3	192-22-008	Button pedal terminal block
CV	302-22-022 302-00-014	Cable of power supply 3X1.5mm with plug Cable of power supply 5X1.5mm
LS	302-22-074	Indicator light overheating motor
K1	302-00-010	Relay motor
FS	302-22-075	Circuit safety fuse 2,5 A
F52	302-22-075	PC Board safety fuse 2,5 A
MB	302-00-005	Blowing Button
MV2	302-00-005	Suction Button
SI	308-00-006	Operation ON-OFF switch
SII	302-00-017	Working surface table ON-OFF switch
SII	302-00-017	Buck's heating operation switch ON-OFF

MONO FASE

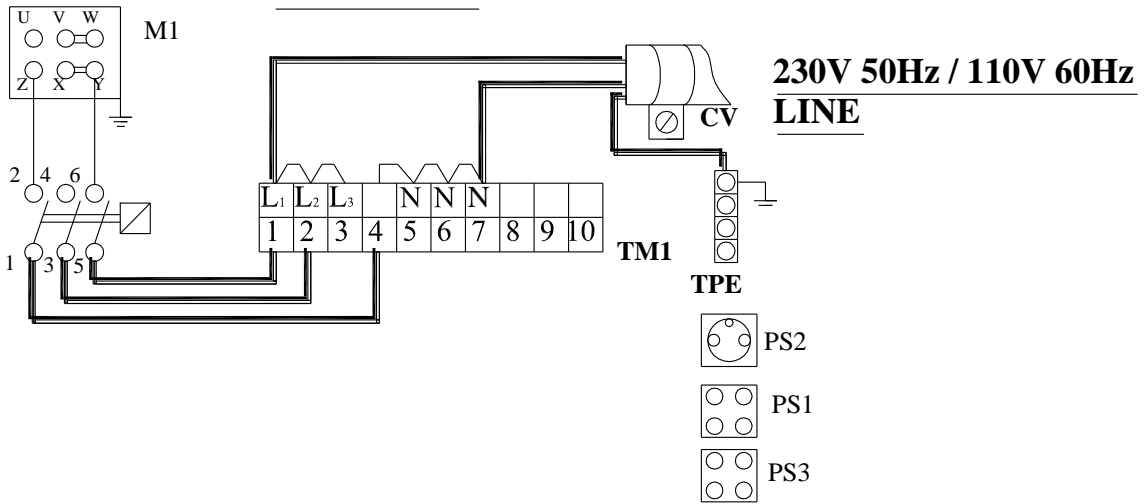

TRIFASE MOTORE MONOFASE

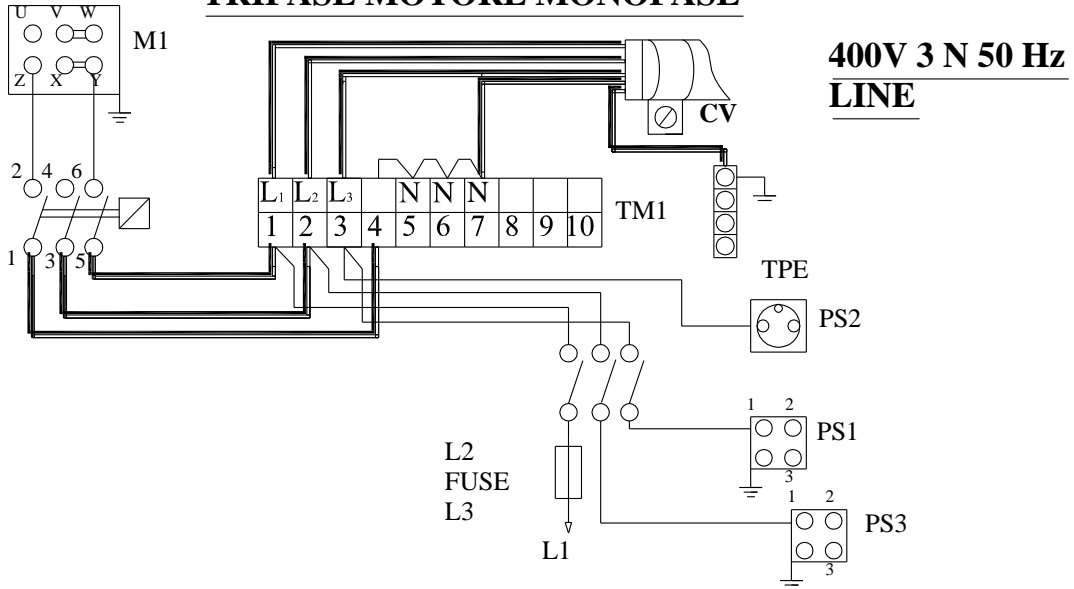

MOTOR 3FASE

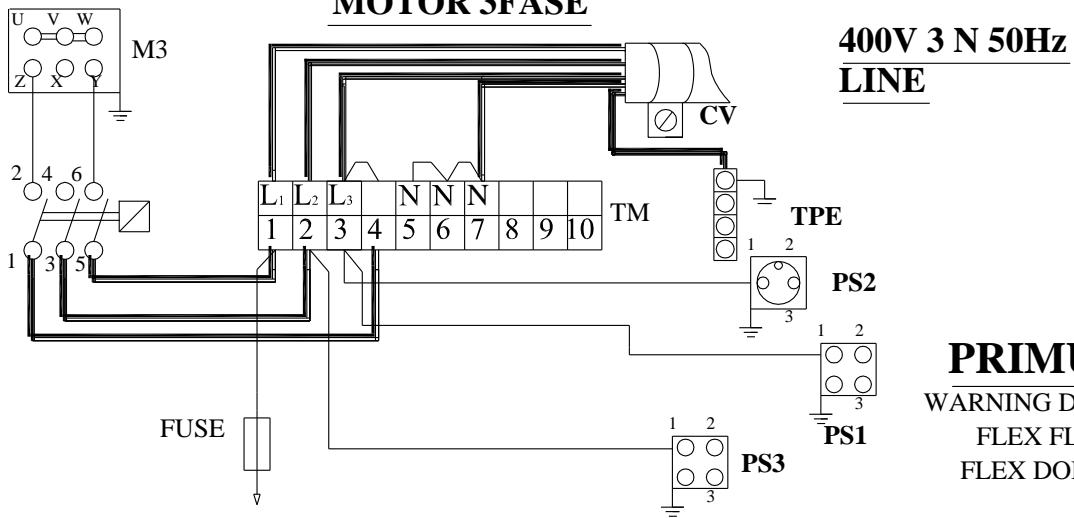

PRIMULA
WARNING DIAGRAM
FLEX FL1365
FLEX DOB 1242

The machine on which you invested is being manufactured according to International and European standards by a company, with an experience in the domain of ironing machines, since 1969.

TECHNICAL ASSISTANCE

For any advice about the operation of the machine or the spare parts, please contact our agents in your territory -----

or directly us in the below address:



14 km. Thessaloniki-Kilkis (Liti)
Tel: 2394071245 Fax: 2394071438
E-mail: info@primula.gr
http: www.primula.gr

Specifications may be subject to change without any prior notice!